

WAL-MART SERVICE AND LAYAWAY LAYOUTS - INSTALLATION/ PRODUCT MANUAL

PAGE # - CONTENTS:

- 2 - CARE AND MAINTENANCE
- 3 - WARRANTY/ TERMS OF CONDITIONS
- 4 - SERVICE/ LAYAWAY COUNTERS
- 5 - LAYAWAY COUNTERS LAYOUT
- 6 - CABINET INSTALLATION INSTRUCTIONS
- 7 - MONITOR STAND ASSEMBLY
- 8 - DEBIT CARD SCREW LOCATIONS

The following basic tools (not included) are needed for installation:

- #2 Phillips head screwdriver or # 2 Robertson head bit with driver.

- Level (4ft or small torpedo)

- Electric or cordless drill *(for installing self tapping screws)*

- (Optional) Silicone – *(for securing units to the floor without using concrete anchors)*

- (Optional) Hammer Drill *(for securing units to the floor using concrete anchors)*



Visit www.ladarling.com/resources or scan the QR code above for the latest assembly instructions.

Care and maintenance:

DO NOT EVER USE ANY CHEMICALS OTHER THAN NOTED BELOW OF ANY KIND TO CLEAN.
ALL CLEANING SHOULD BE DONE USING A SOFT CLOTH OR TOWEL WITH A NON-ABRASIVE MATERIAL.

Laminates/ Melamines/ Kydex surfaces

Clean as needed using a solution of mild dish washing liquid and water. Wipe completely dry with a soft non-abrasive cloth or towel. (Do not leave wet.)

Plexiglass/ Lexan

Clean as needed using a non-abrasive ammonia cleaner and rinse with clean water. Wipe dry with a soft non-abrasive cloth or towel.

Painted Surfaces

Clean as needed using a solution of mild dish washing liquid and water.

For paint scratches

Obtain from local paint supplier. Using paint and paint brush, touch up as needed and allow for drying time as specified from paint can.

Stainless Steel Surfaces

Clean with non-abrasive ammonia cleaner and clean water. Wipe completely dry with a soft non-abrasive cloth or towel. **WARNING:** High-strength cleaners and some harsh cloths will scratch and damage the protective coating on stainless steel and make it susceptible to corrosion.

Warranty/ Terms and conditions of sale:

This document, including these Terms and Conditions (this "Agreement") supercedes all other agreements, oral or written, represents the final and complete understanding of the parties, and may be amended or cancelled only by written agreement signed by both parties. This agreement expressly limits acceptance to these terms; no other terms shall have any force or effect until acknowledged in writing by Seller. Any proposal for additional or different terms is hereby deemed material and is objected to and rejected. Unless otherwise stated herein, Buyer's receipt of any portion of the Goods shall constitute acceptance of this Agreement unless Buyer immediately rejects and returns all such Goods.

1. Limited Warranty:

- a) Seller warrants that the Goods will conform to the descriptions and specifications incorporated herein, and will be free from defects in materials and workmanship under normal use and service for one year from the date of shipment. THESE ARE SELLER'S ONLY WARRANTIES. SELLER MAKES NO OTHER EXPRESS OR IMPLIED WARRANTIES WHATSOEVER. ALL IMPLIED WARRANTIES OF MERCHANTABILITY AND/OR FITNESS FOR A PARTICULAR PURPOSE ARE HEREBY DISCLAIMED AND EXCLUDED.
- (b) If Buyer or any other person, without the prior written consent of Seller, repairs or modifies all or part of the Goods, or if the Goods are not installed or used in compliance with Seller's directions, this warranty shall be void.
- (c) If Buyer notifies Seller in writing within the warranty period of a defect in materials or workmanship in any Goods, and if Seller determines that such Goods are not in accordance with the warranty, Seller will repair or replace, at its sole option, the defective goods provided Buyer returns such Goods to Seller's plant freight prepaid. No Goods shall be returned without Seller's prior approval. This shall be Buyer's exclusive remedy for seller's liability hereunder.
- (d) Seller's liability to Buyer or anyone claiming through or on behalf of Buyer, with respect to any claim or loss arising out of this transaction or alleged to have resulted from an act or omission of Seller, whether negligent or otherwise, and whether in tort, contract or otherwise, including failure to deliver, delay in delivery, or breach of warranty, shall be limited to an amount equal to the purchase price of the Goods or part thereof with respect to which such liability is claimed or, where appropriate and at the option of Seller, to replacement of the Goods or part hereof. IN NO EVENT SHALL SELLER BE LIABLE FOR INCIDENTAL OR CONSEQUENTIAL DAMAGES, LOSSES, OR EXPENSES ARISING OUT OF THIS TRANSACTION.

2. Indemnification:

- (a) If any Goods are to be furnished to Buyer's designs, Buyer agrees to defend, indemnify and save Seller harmless against all liabilities and expenses resulting from any claim that such Goods infringe upon any patents or other intellectual property rights held by third parties. Buyer also agrees to defend, indemnify and hold harmless against all claims and expenses arising out of the mishandling, abuse or misuse of the Goods and if installation of the Goods was not done by Seller's agents, also against any claims and expenses arising out of such installation.
- (b) Excluding Goods manufactured to Buyer's designs, Seller shall defend, at its expense, any suit or proceeding brought against Buyer claiming that the Goods infringe upon any patents or other intellectual property rights held by third parties, provided that Seller is promptly notified of such claim. If the Goods are deemed to infringe, Seller shall, at its expense and sole option, either procure for Buyer the right to continue using the Goods, replace them with non-infringing Goods, modify them so they become non-infringing, or remove them and refund the purchase price to Buyer.

3. Risk of Loss:

All risk of loss or damage to Goods shall pass to Buyer upon delivery to Buyer or its designated agent, or to a carrier for delivery to Buyer, whichever first occurs. Buyer shall be responsible for filing and prosecuting any claim for damage or loss in transit directly with the carrier.

4. Delivery and Delays:

All shipping and delivery dates are estimated and are based upon prompt receipt of all necessary information from Buyer. Seller shall not be liable for any delay in or failure of performance due to any contingency beyond Seller's reasonable control, including (but not limited to) acts of God, civil commotion, labor disputes, explosions, fires, flooding, embargoes, delay of carriers, or government regulations or requirements whether valid or invalid. Orders changed by Buyer within (2) weeks of shipment date will be subject to charges.

5. Returns:

Non-standard fixtures manufactured to Buyer's designs and specifications are not subject to return, cancellation, change reduction in quantity or suspension of deliveries. No returns are allowed unless approved in writing by Seller's Return Goods Authorization. A re-packing and restocking charge of 20% of the invoice price will be assessed on all returned Goods, and only unused, undamaged merchandise in the original packaging will be authorized for return. Product returned that is store specific such as cabinets and kiosks with store specific locks and keys will be assessed a 40% restocking fee. Damaged products will be disposed of at L.A. Darling's discretion.

- LAD# 35398300C215
- 4' SERVICE COUNTER SINGLE MONITOR MOUNT
- WMT SAP# 100578275

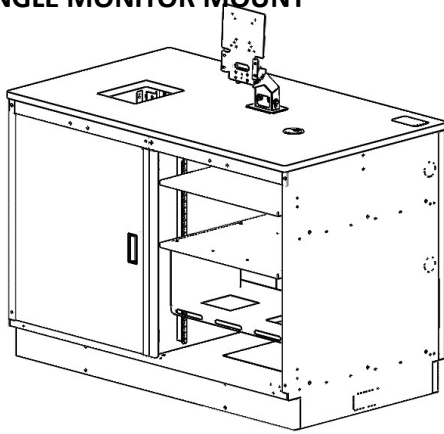

- LAD# 35398400C215
- 5' SERVICE COUNTER SINGLE MONITOR MOUNT
- WMT SAP# 100647165

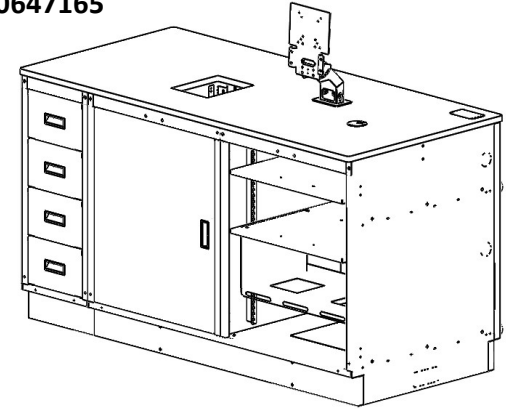

- LAD# 35398500C215
- 6' SERVICE COUNTER SINGLE MONITOR MOUNT
- WMT SAP# 100578276

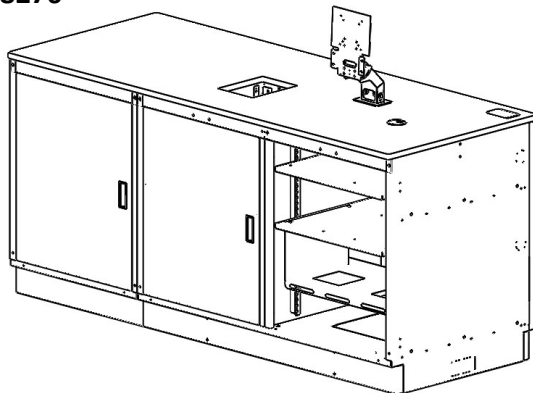

- LAD# 35398600C215
- 8' SERVICE COUNTER SINGLE MONITOR MOUNT
- WMT SAP# 100578277

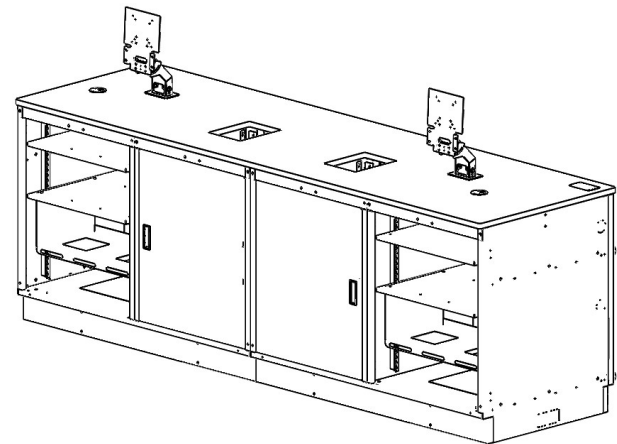

SERVICE COUNTER AND LAYAWAY LAYOUT

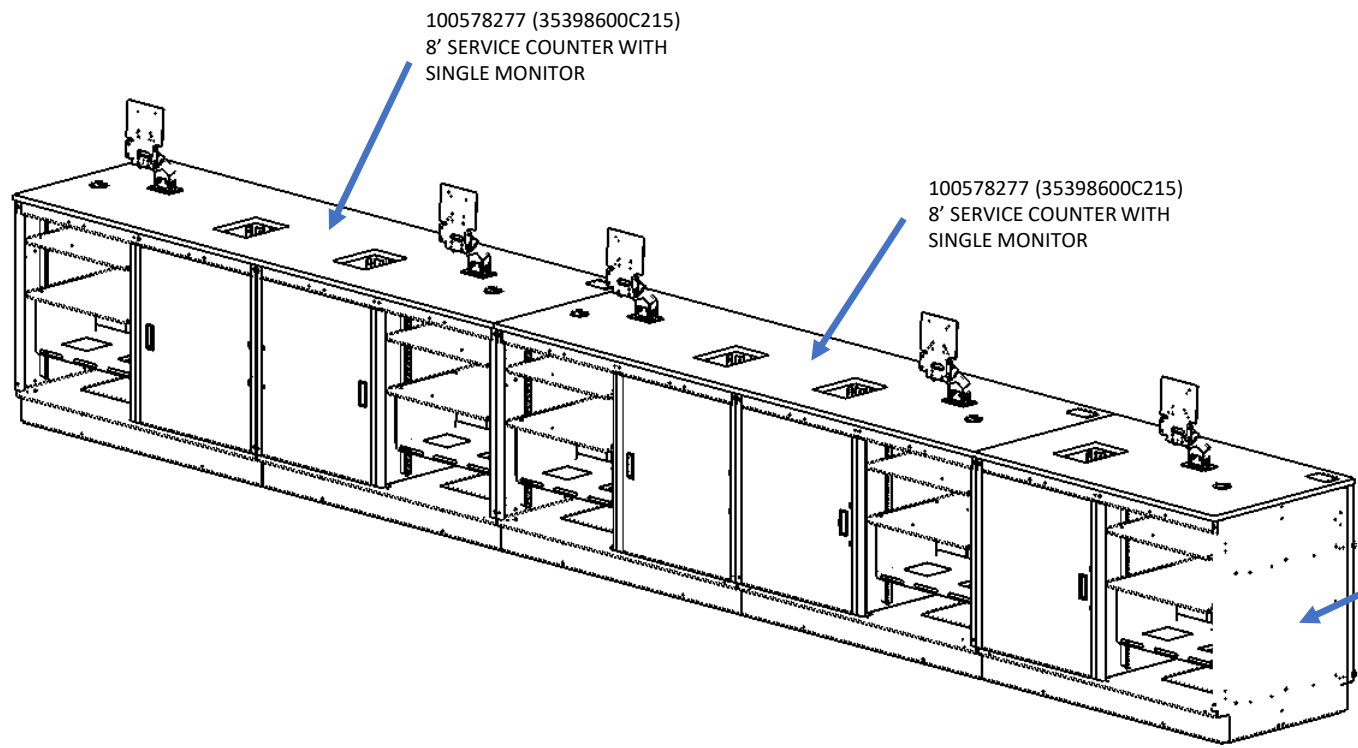

100578277 (35398600C215)
8' SERVICE COUNTER WITH
SINGLE MONITOR

100578277 (35398600C215)
8' SERVICE COUNTER WITH
SINGLE MONITOR

100578275 (35398300C215)
4' SERVICE COUNTER WITH
SINGLE MONITOR

WARNING !

IMPORTANT SAFETY INSTRUCTIONS

YOUR PERSONAL SAFETY IS AT RISK !



While lifting or moving any heavy object for your safety always use the Team Lift Approach to minimize the risk of injury.

Cabinet Installation Instructions:

- Step #1 From floor plan, place 1st cabinet in location as specified from construction floor plans.
- Step #2 Using a level, level the cabinet side to side and total length using shims placed between floor and base of cabinet.
- Step #3 Remove hole knockouts on side panels as needed for electrical pass thru. Use a soft blow hammer to remove.
- Step #4 From the floor plan, place the second cabinet in the location specified and repeat Steps #2 and #3 for this cabinet. Repeat again for all cabinets in layout.
- Step #5 From inside end of 1 of the adjacent cabinets, use a cordless drill & a #2 Phillips bit to secure the 2 cabinets together using self tapping screws provided in hardware package. See detail at right.
- Step #6 Secure remaining adjacent cabinets as required per floor plans repeating above steps.
- Step #7 Secure monitor mounts as shown on next page.
- Step #8 Secure all cabinets to floor using a ¼" bead of clear silicone where base of cabinets meets the floor. Allow minimum 24-hour period for silicone to fully cure securing cabinets to floor. (FOR SEISMIC STORES, ANCHOR TO FLOOR PER STATE REQUIREMENTS WITH FLOOR ANCHORS.)

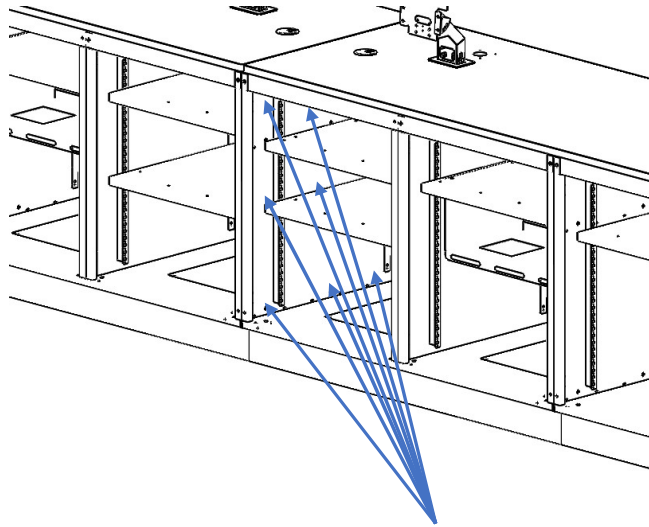

SECURE CABINETS AT JOINTS
USING 10 - SELF DRILLING SCREWS
PROVIDED

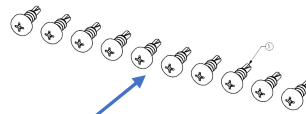

#8 X ½" SELF
DRILLING SCREWS

WARNING !

IMPORTANT SAFETY INSTRUCTIONS

YOUR PERSONAL SAFETY IS AT RISK !



While lifting or moving any heavy object for your safety always use the Team Lift Approach to minimize the risk of injury.

NOTE:

LOWER SECTION OF MONITOR STAND SHOULD ALREADY BE ATTACHED TO UNDERSIDE OF COUNTERTOP.

SECURE UPPER SECTION OF MONITOR STAND USING (3) ¼-20 X ½" HEX HEAD BOLTS AND (3) ¼" FLAT WASHERS PROVIDED.

53627901BH – SINGLE MONITOR HARDWARE KIT CONSIST OF:
#1 - 4EA RD HD MS #8 X ¼"
#2 – 4EA RD HD MS #8 X ¾"

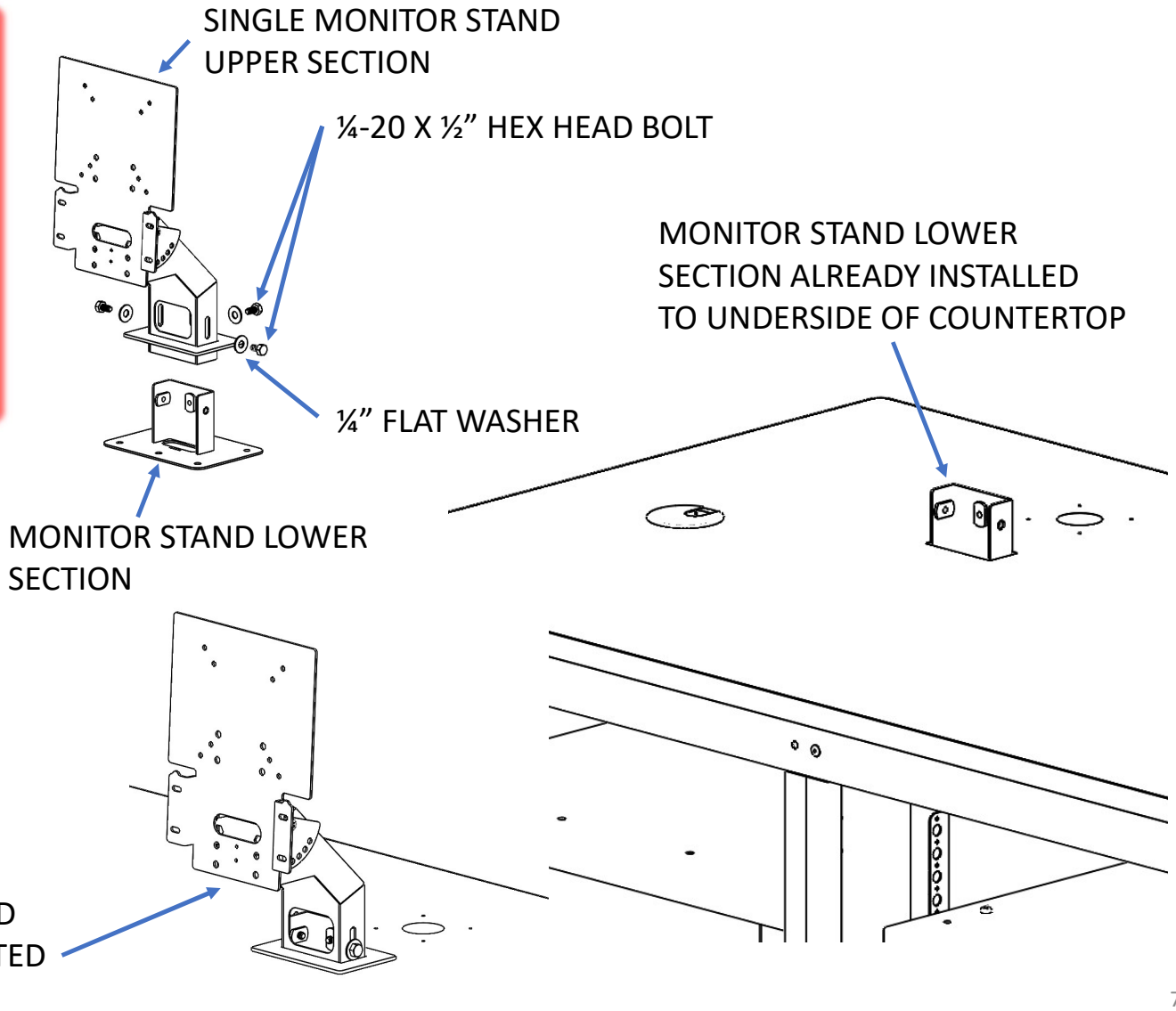
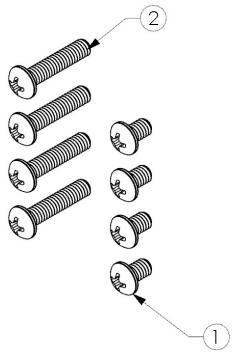

DEBIT CARD SCREW LOCATIONS

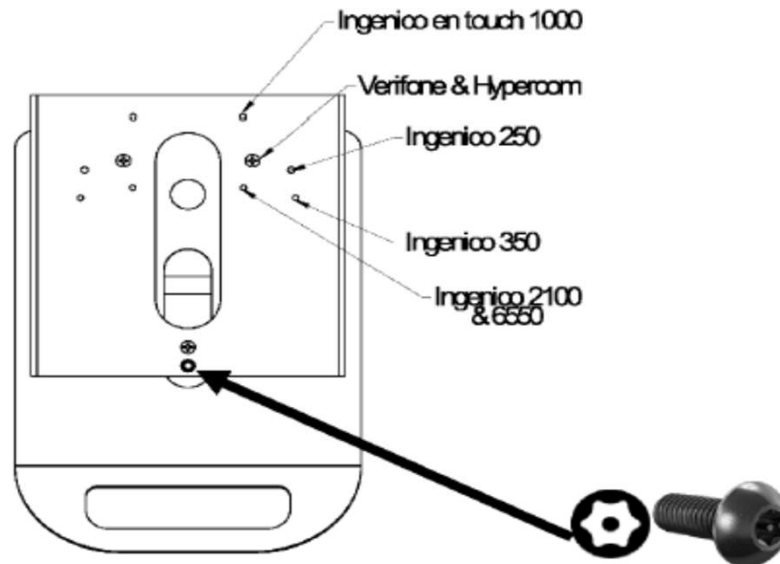

Mounting Screws for INGENICO brand card readers



Mounting Screws for VERIFONE & HYPERCOM brand card readers



T25 TORX Security Screw used for all card readers to lock card Reader to the bracket for safety and security of device. T25 TORX Security Screw is accessed from the back side of the card reader mounting bracket.

TOOL REQUIREMENTS:

- (1) Cordless or corded drill with a #2 Phillips bit to insert the Mounting Screws into the debit card mounting plate.
- (1) T25 TORX Security Bit to tighten debit card reader locking screw

*****NOTE***** Failure to use the correct mounting screws for the specified brand of card reader or utilizing the T25 TORX Security Screw may result in damage or theft of the device.