

Walmart Part No. **100674473**
100674455
100673476
100673542
100688157

Walmart Description
RISER TOP ASSEMBLY 18X48
RISER TOP ASSEMBLY 12X48
4X4 VIGNETTE BASE CABINET 48X48X18 IN
VIGNETTE RISER 23X48X15 IN
VIGNETTE BUMPER KIT 6PC

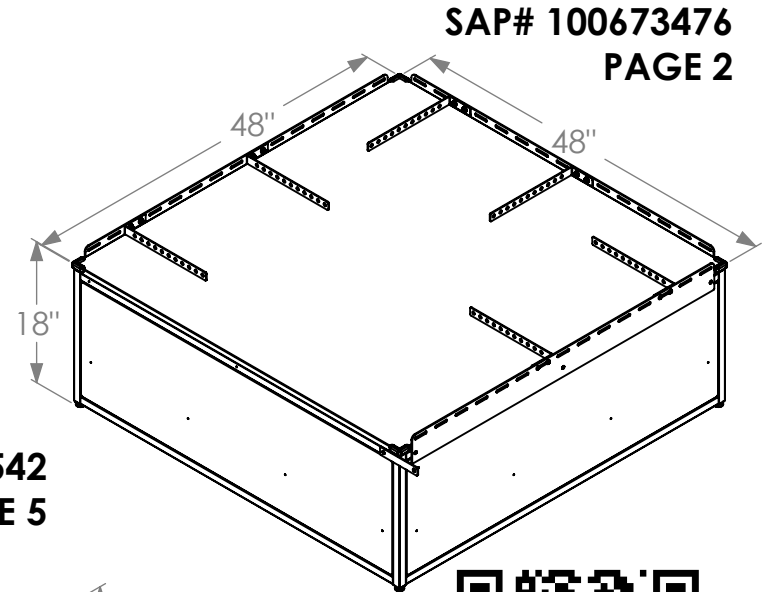

Scan the QR code or visit
www.ladarling.com/vignette-base/ for the
latest copy of the instruction sheets.

Customer Service 1-800-682-5730

PAGE
1 OF 7

LA DARLING

REDEFINE. RETHINK. RETAIL SOLUTIONS.

LAD DESCRIPTION
VIGNETTE BASE DISPLAYS

LAD PART NO.
354302IS

REV.	BY	DATE
6	RP	8/10/23

Step 1: Locate Vignette Bases according to floor plan.

Step 2: Attach tie down plates where needed using provided flat head screws.

Step 3: Attach extender brackets to tie down plates where needed using provided 1/4"-20 screws and nuts.

Step 4: If multiple Vignette Bases are used, connect them using provided #10×3/4" flat head screws and vignette tie plates.

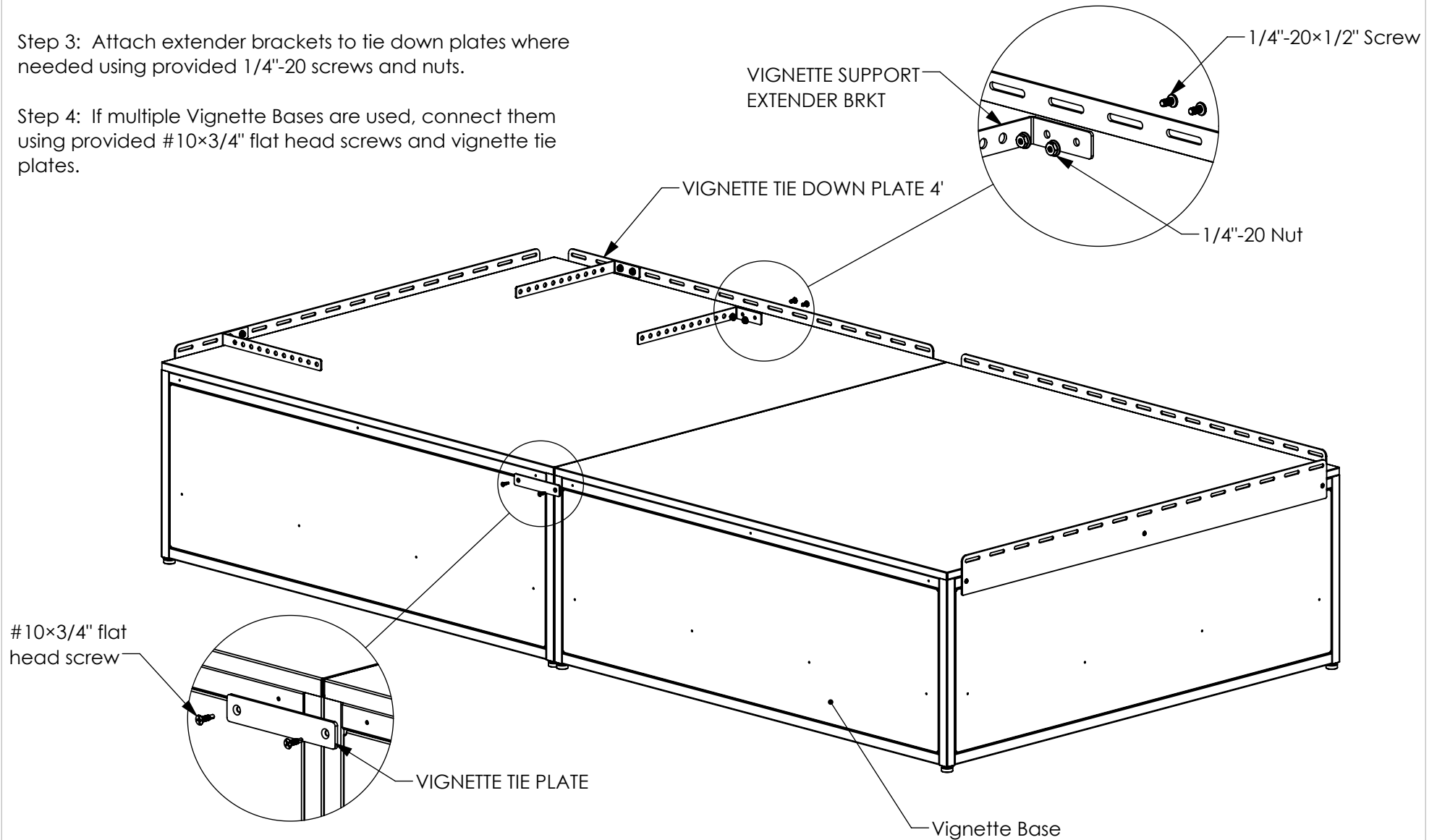

Step 4A: Where tie down plates are used, connect the Bases with the vignette tie plate on top of the tie down plates.

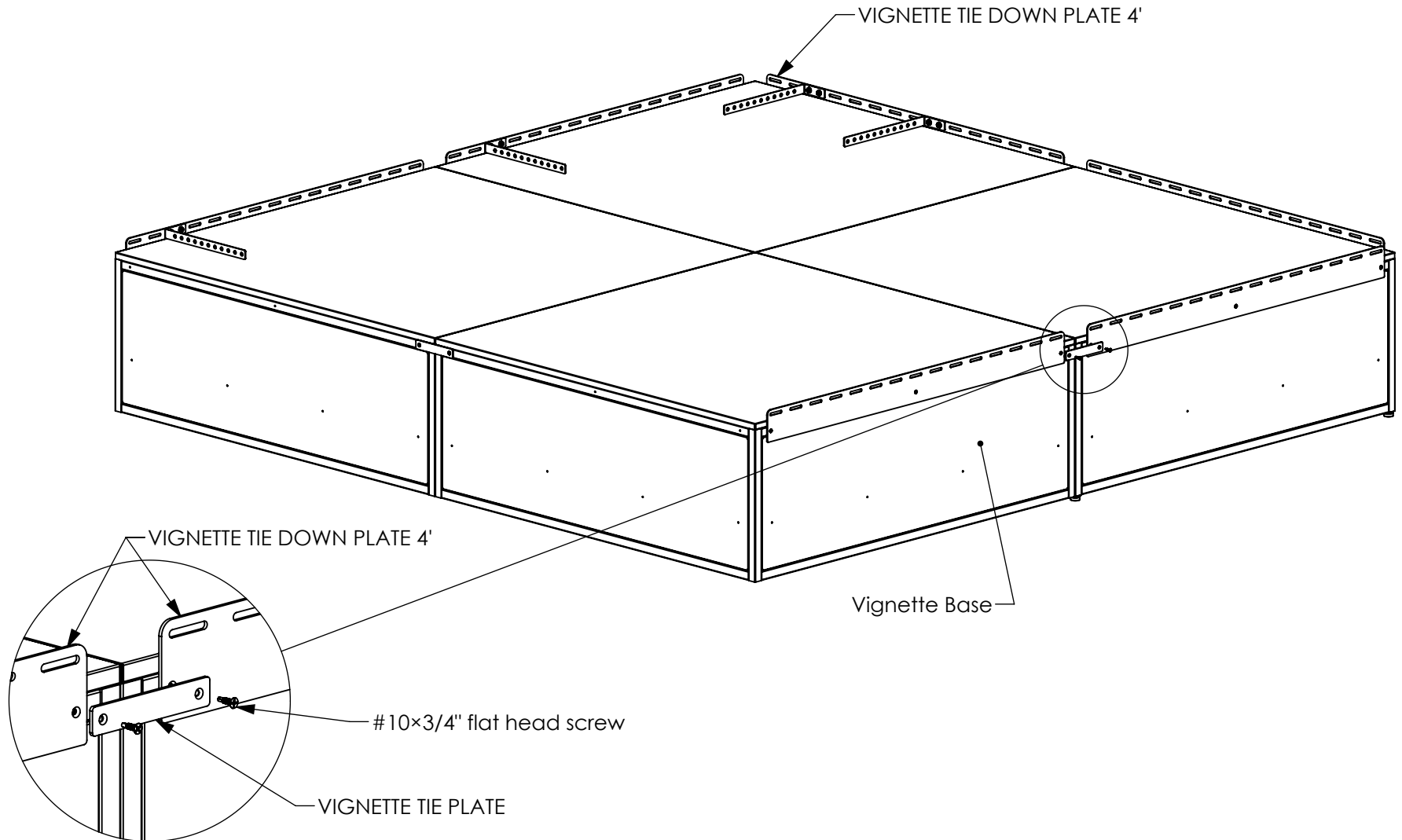

LAD DESCRIPTION			
VIGNETTE BASE DISPLAYS			
LAD PART NO.	REV.	BY	DATE
354302IS	6	RP	8/10/23

Step 5: For displays that use Risers, attach Risers using a Vignette Tie Plate LH and a Vignette Tie Plate RH on each end of Riser with flat head screws. See page 4 for Vignette Risers with solid sides.

Step 6: Attach self-adhesive corner covers to exposed corners on Vignette Bases and Risers.

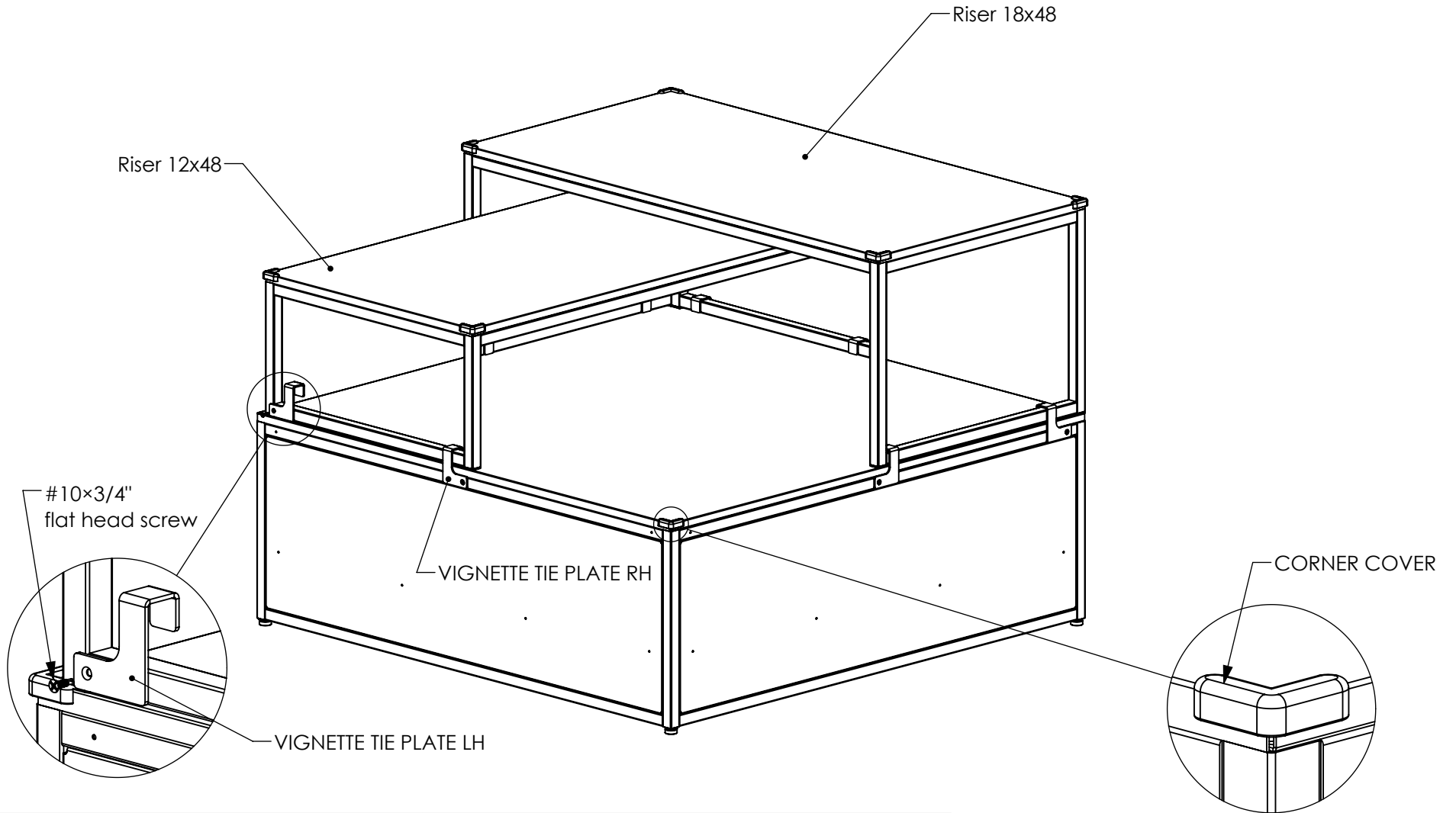

Step 5: For displays that use Vignette Risers, set Vignette Riser on base, ensuring that all four rubber feet rest on Vignette Base and side angles wrap over sides of Vignette Base.

Step 6: Attach self-adhesive corner covers to exposed corners on Vignette Base.

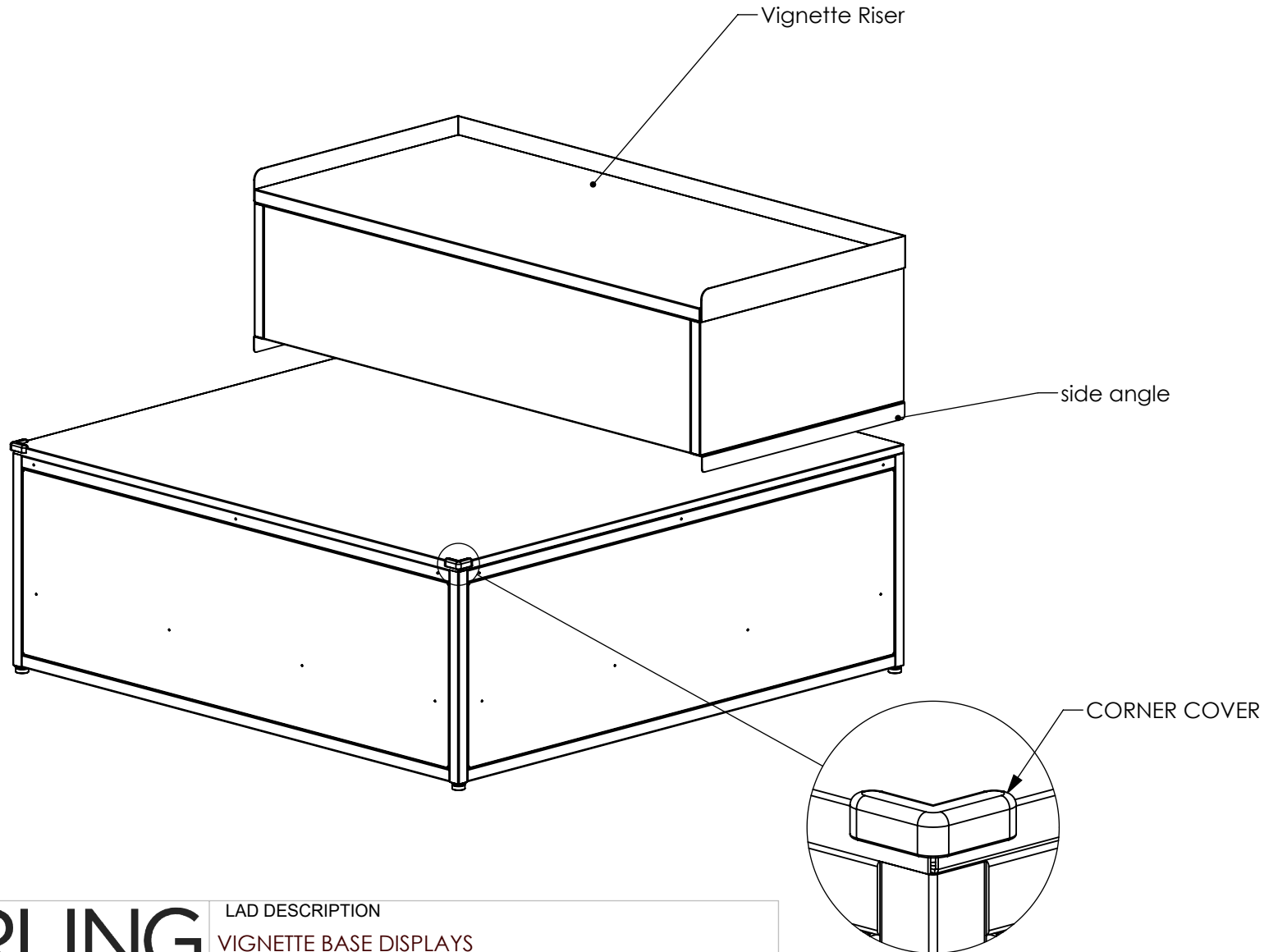

Step 7: Connect end caps on ends of bumper track. Ensure that gap between end caps matches length of bumper cover.

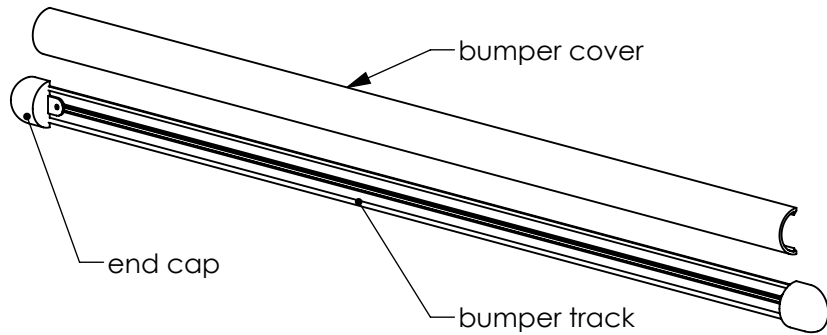

Step 9A: Position bumpers so that end caps are directly below marks and ~1/8" from ends of Vignette Base on both ends. Install self drilling screw through holes on end caps. Install 2 self drilling screws on center of bumper track between end caps.

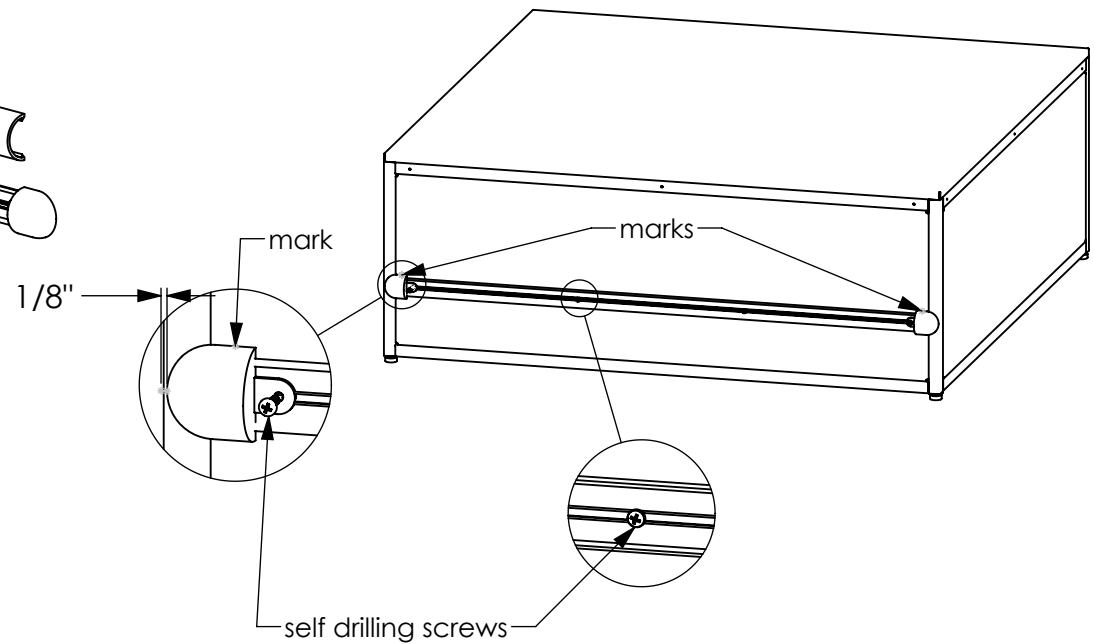

Skip to Step 8B for Vignette Bases with predrilled holes.

Step 8A: On Vignette Bases without predrilled bumper mounting holes, use tape or non-permanent marker to mark both ends 7 1/16" from the bottom of the frame.

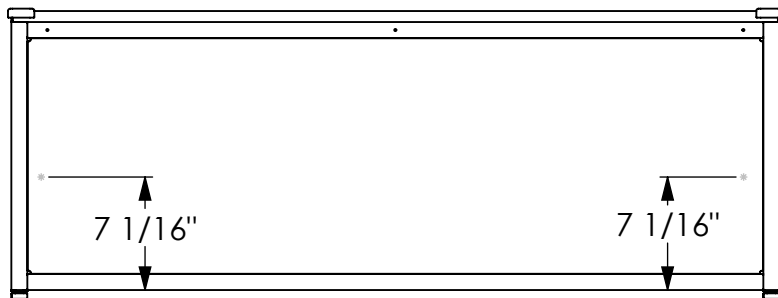

Step 8B: On Vignette Bases with predrilled bumper mounting holes, attach the bumper with self drilling screws through the end caps into the predrilled holes.

Optional: Drill holes in bumper track through end cap holes to aid in aligning with predrilled holes.

Step 9B: Install 2 self drilling screws on center of bumper track between end caps.

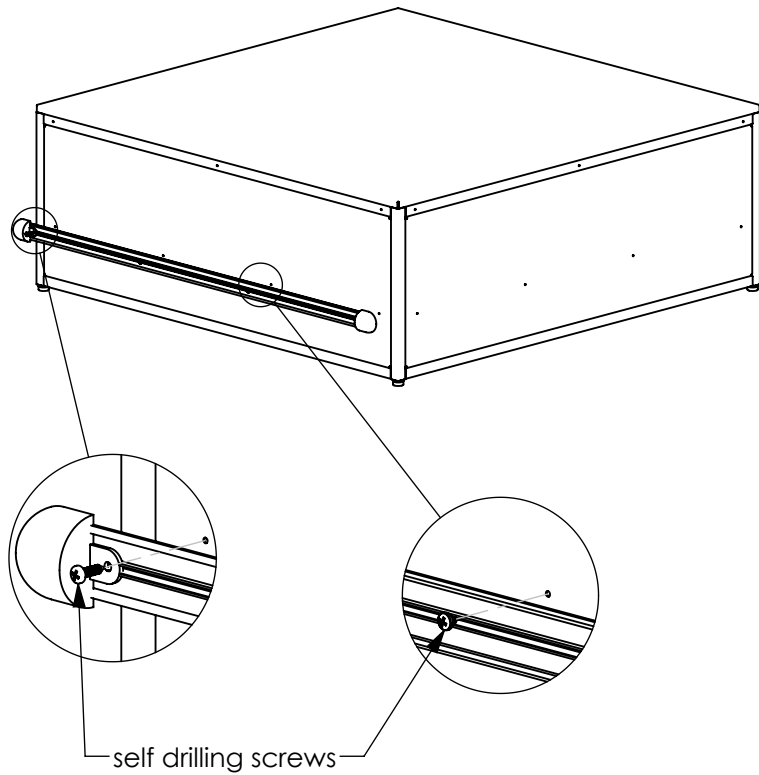

Step 10: Snap bumper cover onto bumper track. Repeat steps to install bumpers on other sides of Vignette Bases.

