

Step 1: Install toppers into rack.

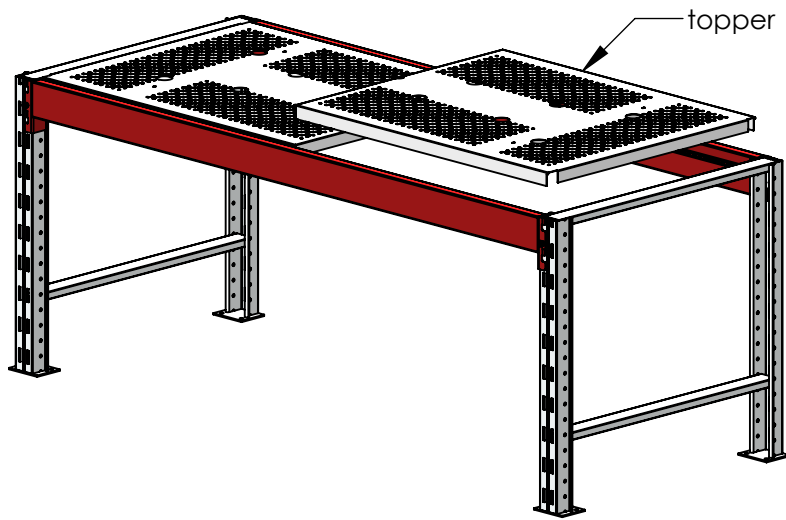

Step 3: Secure risers to toppers with screws.

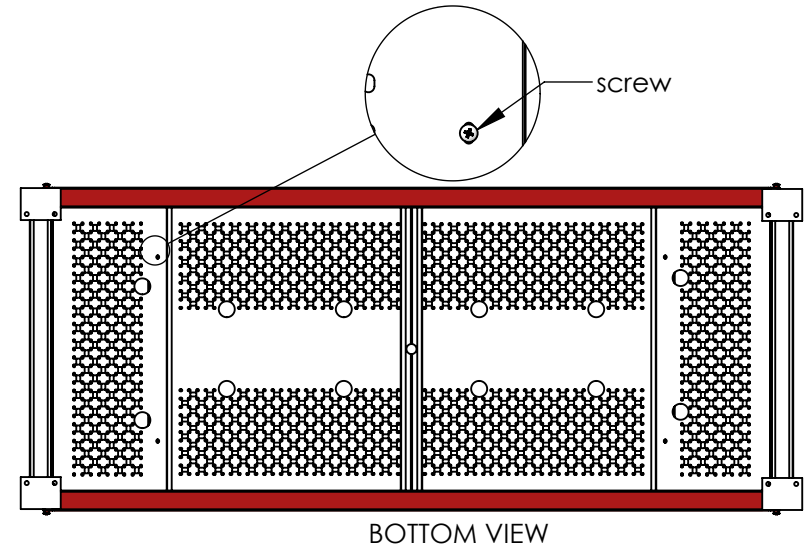

Note: Steps 2 & 3 only apply when using SAP# 100662822 & 100662821.

Step 2: Center risers on toppers.

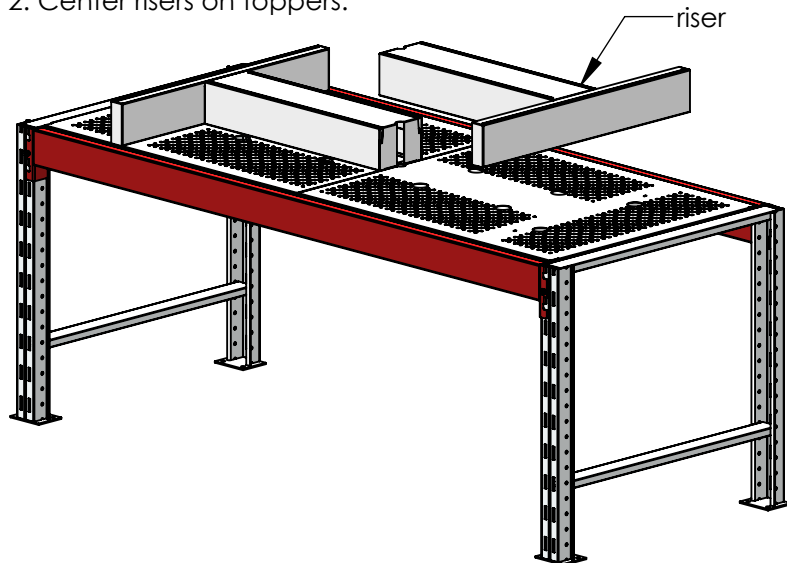

Step 4: Attach hooks to holes under toppers.

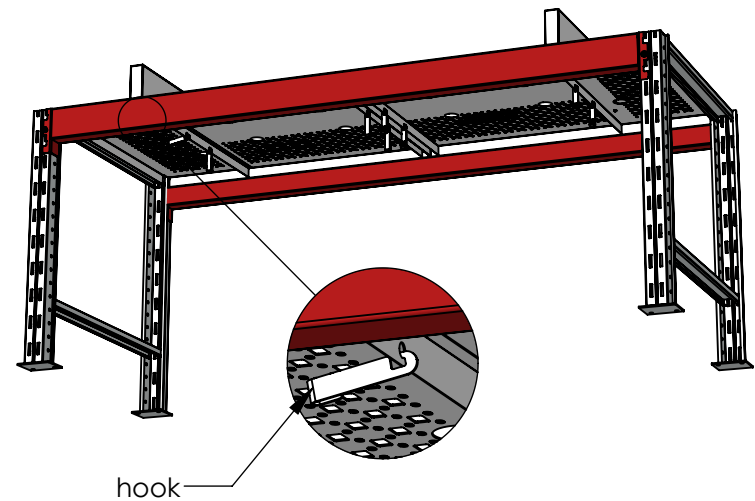

Step 4: Attach grids to lower portion of hooks. Secure grid to hooks with cable ties.

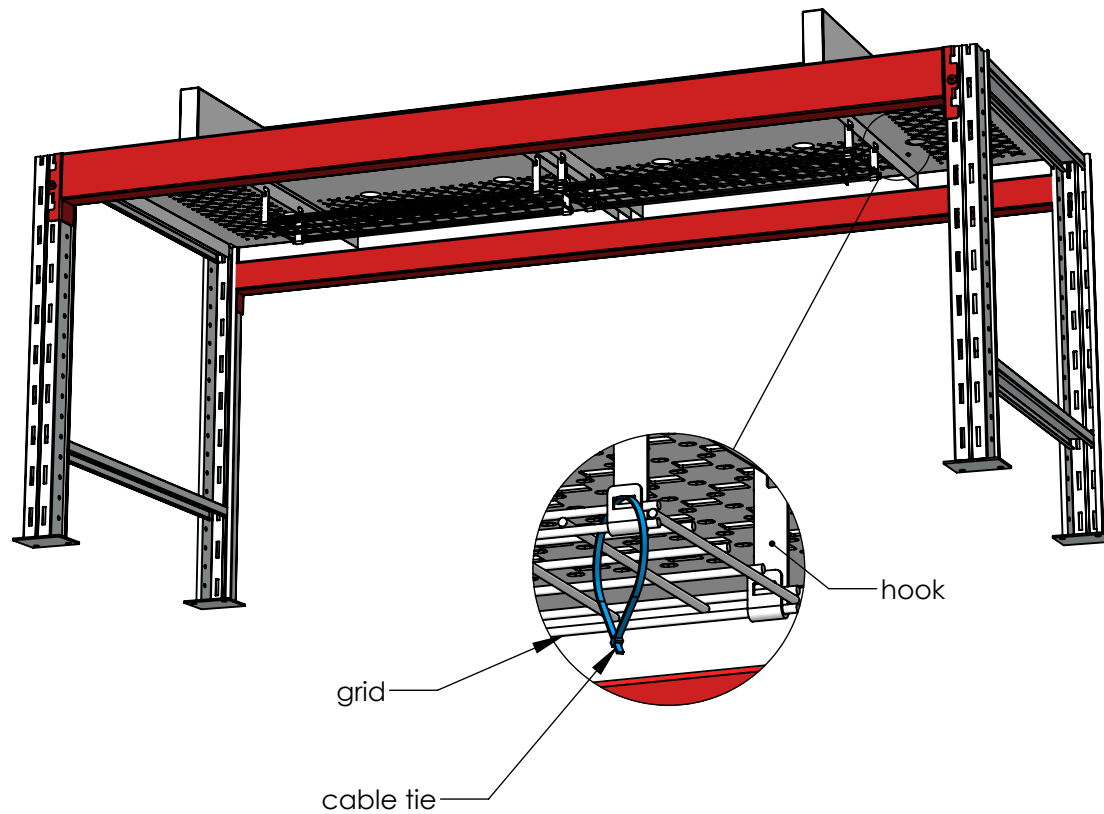

LAD DESCRIPTION			
TOPPER & RISER INSTRUCTIONS			
LAD PART NO.	REV.	BY	DATE
202093IS	2	RP	12/6/23

