

CORRAL WALL STR 48
 SAP P/N: 100664503
 LAD P/N: 35420248C215

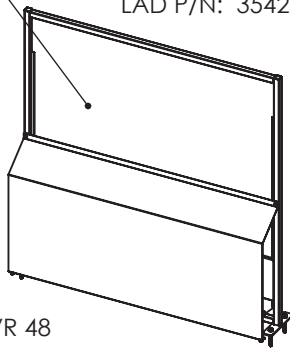

CORRAL WALL AO 15
 SAP P/N: 100664507
 LAD P/N: 35420315C215

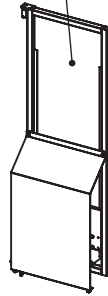

CORRAL WALL AO 30
 SAP P/N: 100664506
 LAD P/N: 35420330C215

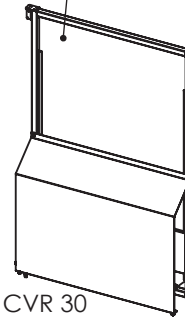

CORRAL WALL AO 48
 SAP P/N: 100664504
 LAD P/N: 35420348C215

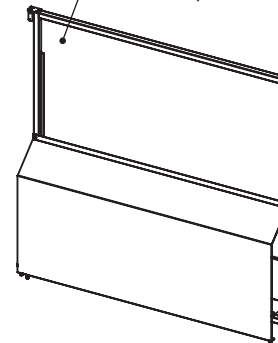

CORRAL WALL AO 48 W/ CUT OUT
 SAP P/N: 100664505
 LAD P/N: 35421248C215

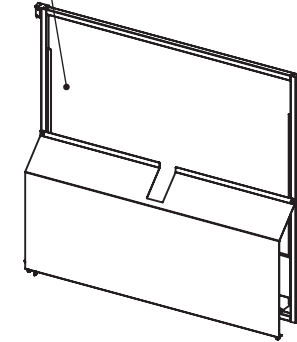

CORRAL WALL STR NO CVR 48
 SAP P/N: 100658697
 LAD P/N: 35421448C215

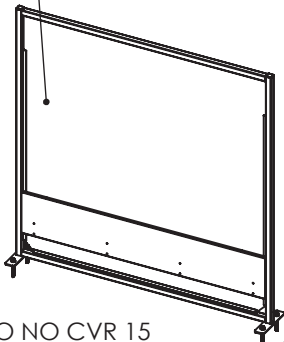

CORRAL WALL AO NO CVR 30
 SAP P/N: 100658699
 LAD P/N: 35421330C215



CORRAL WALL AO NO CVR 48
 SAP P/N: 100658698
 LAD P/N: 35421348C215

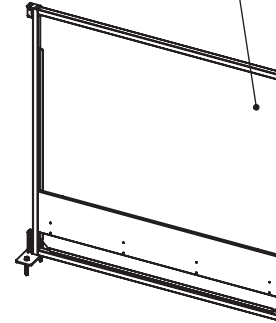

WALL CORNER KIT
 SAP P/N: 100664508
 LAD P/N: 40062200C215

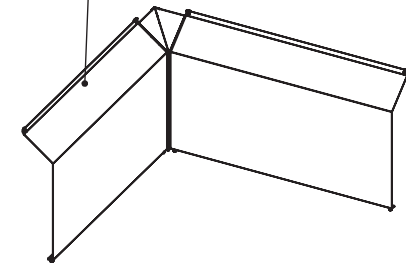

CORRAL WALL AO NO CVR 15
 SAP P/N: 100658770
 LAD P/N: 35421315C215

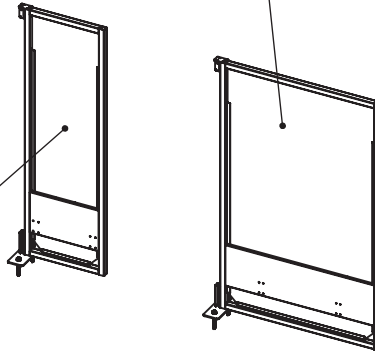

8" SPANNER KIT FOR HALF GONDOLA 30
 SAP P/N: 100666113
 LAD P/N: 40061830C215

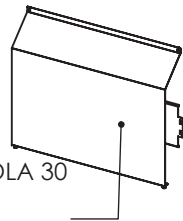

8" SPANNER KIT FOR HALF GONDOLA 48
 SAP P/N: 100664509
 LAD P/N: 40061848C215

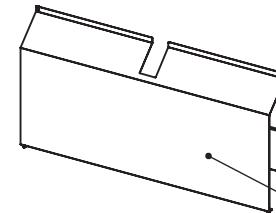
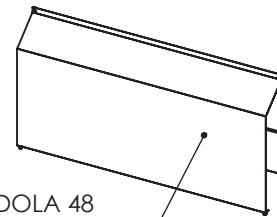

8" SPANNER KIT W/ PASS THRU HG 48
 SAP P/N: 100664650
 LAD P/N: 40062148C215

Step 1: Assemble wall sections per layout drawing. Adjacent wall sections share bottom and top connector plates. Wall dead ends use end anchor plates and gray end caps.

Step 2: Install wire baskets in holes on the front side of the frames (facing inside of checkout area).

Step 3: Install wood hardboard panels into frame channels from the back side of the frames.

Step 4: Anchor frames to the floor using provided wedge bolts.

Step 5: Attach power outlet boxes to frames where needed, and run conduit through wire baskets.

Step 6: Attach cover panels magnets to frames. Adjust levelers as needed. Power drop locations will use the notched cover panels.

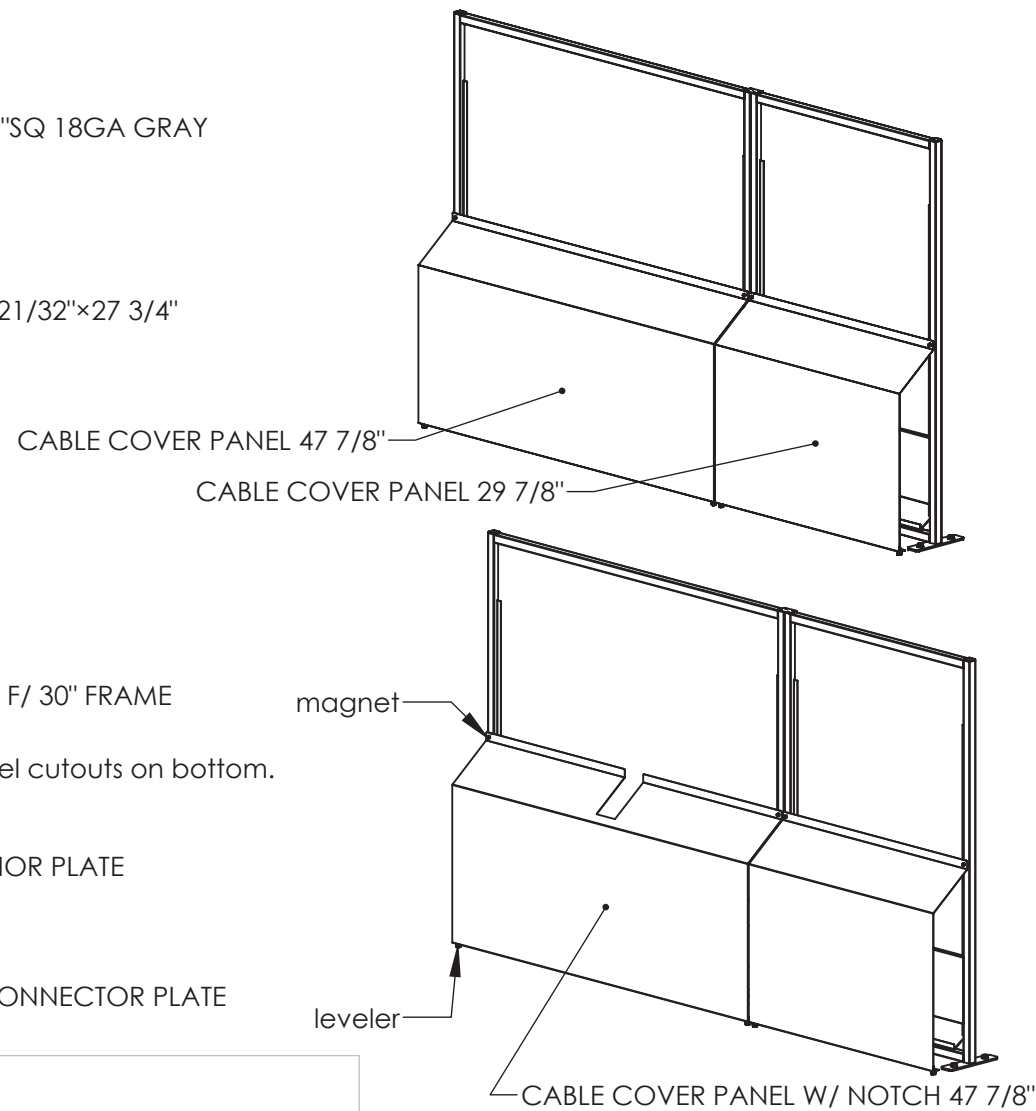
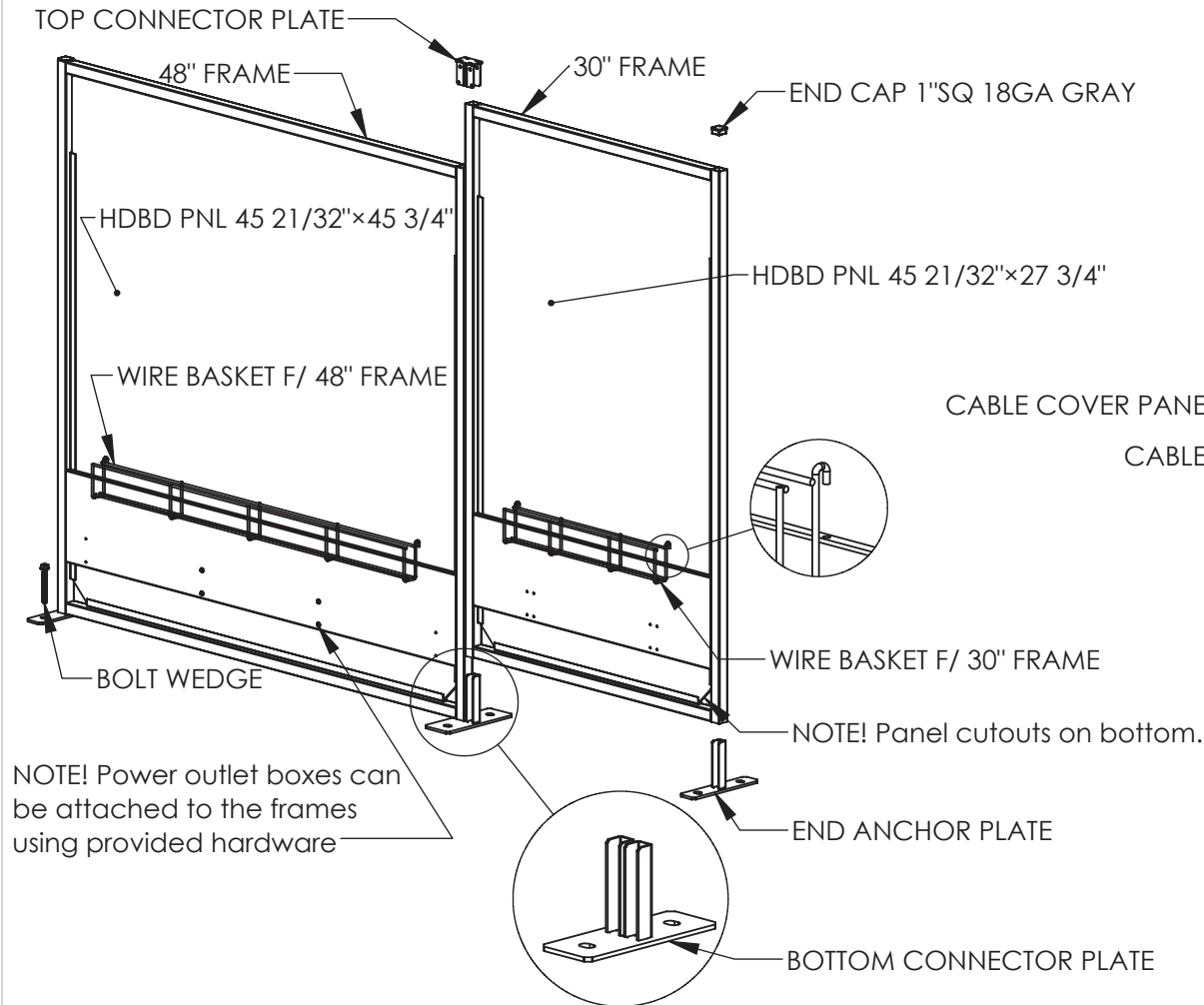

Step 1: Assemble wall sections per layout drawing.

Step 2: Install corner cover by attaching magnets to frames.

Step 3: Run conduit through wire baskets and corner cover.

Step 4: Attach 40 21/32" and 41 21/32" cover panels to frames and corner cover.

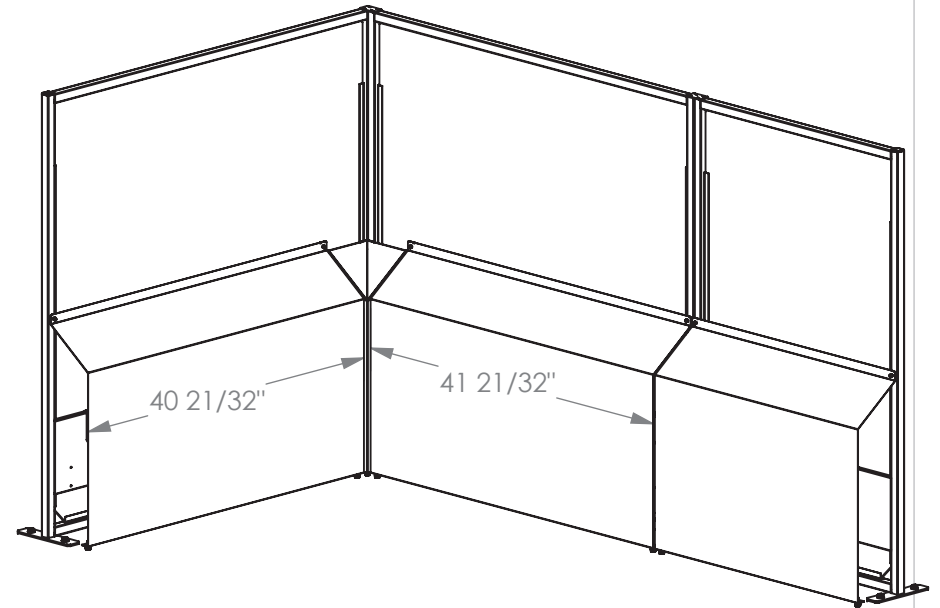
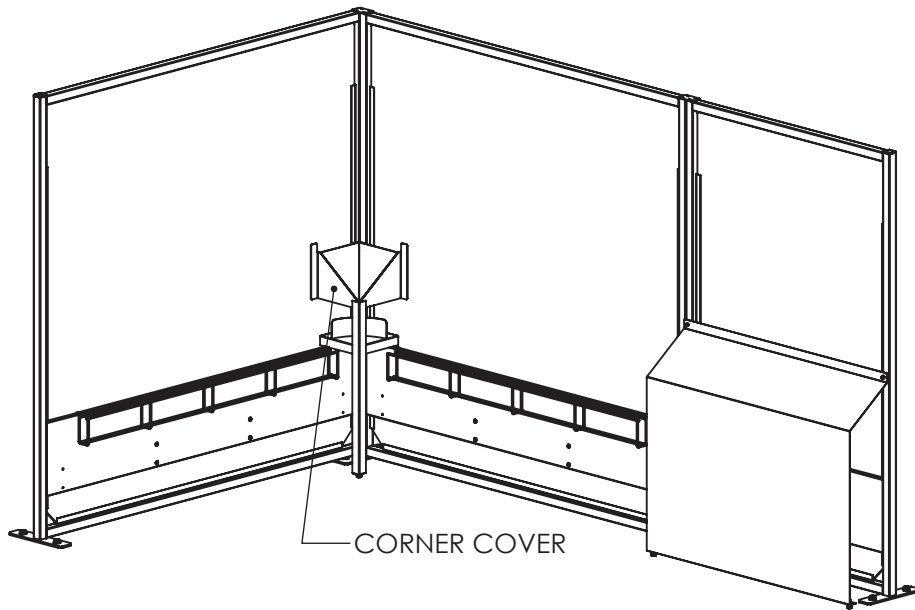

Install 15" wall panels without covers as shown below at the checkout area exits, matching layout drawing.

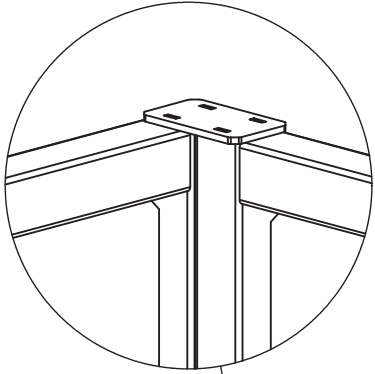

CORRAL WALL AO NO CVR 15
SAP #: 100658770

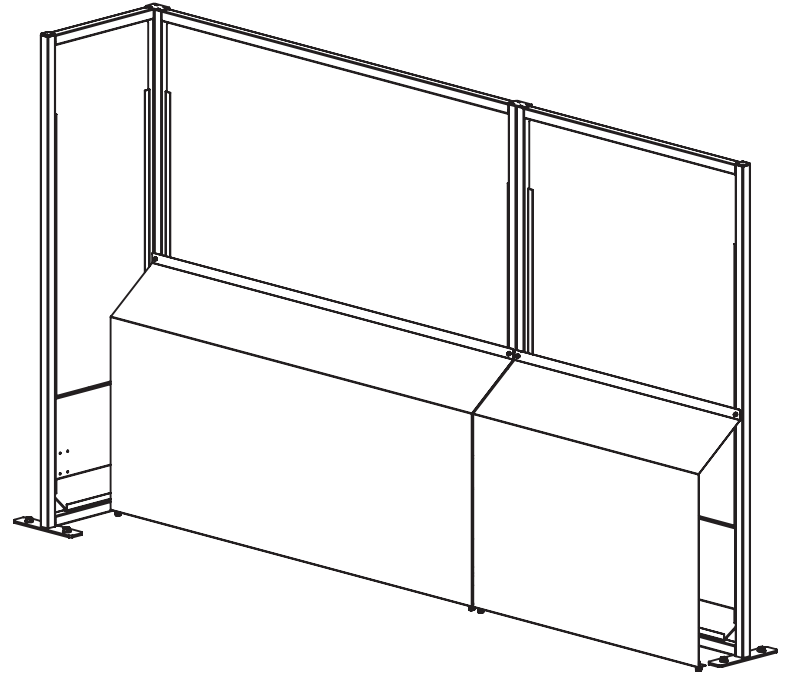
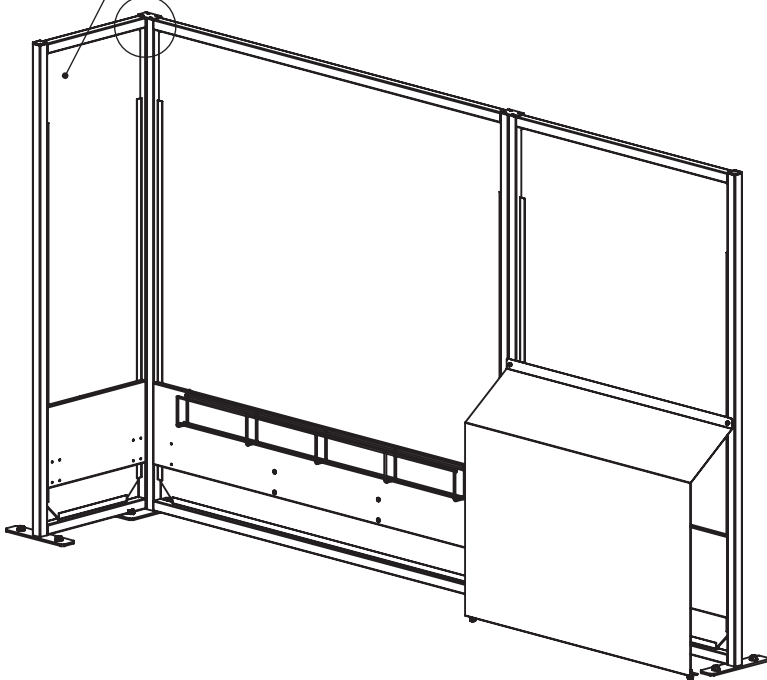

Step 1: Install 8" spanner channels on the back side of half gondolas that are on the perimeter of the checkout area. Hook the spanners in the holes on the back of the half gondola so that they are approximately 6 1/8" above the floor.

Step 2: Attach power outlet boxes to spanners where needed, and run conduit through wire baskets.

Step 3: Attach the cover panel magnets to the channels on the uprights. Adjust levelers as needed. Power drop locations will use the notched cover panels.

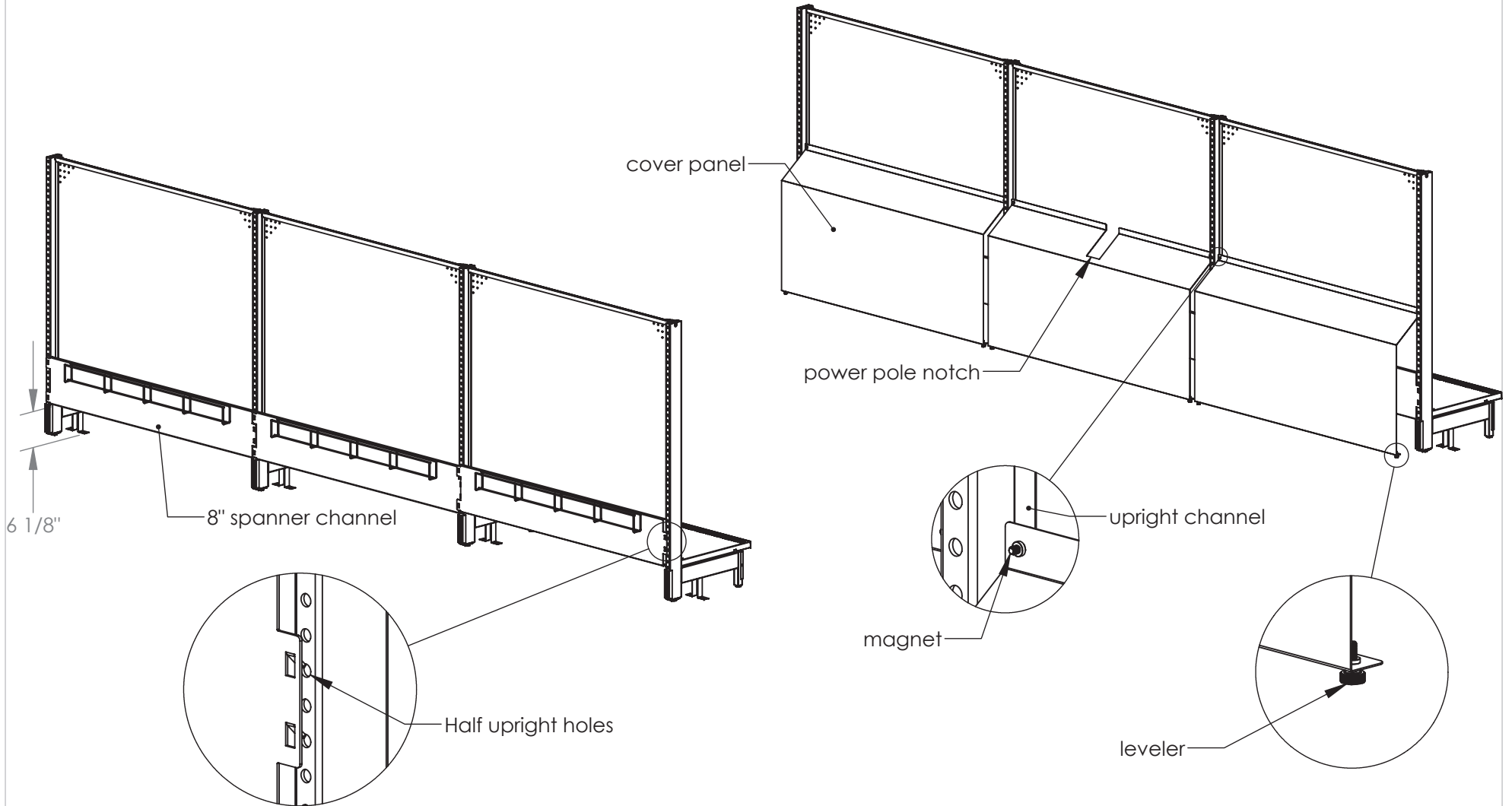

LAD DESCRIPTION		
FET WALL - HALF GONDOLA		
LAD PART NO.	REV.	DATE
354202IS	1	12/22/20
BY	DATE	
RP	12/22/20	