

**BAGGER CAB STR 29X24**  
100673746

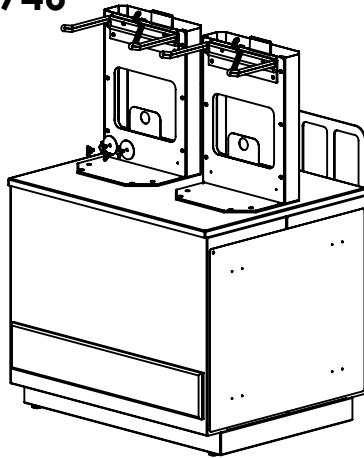

**BAGGER CAB AO 29X24**  
100673842

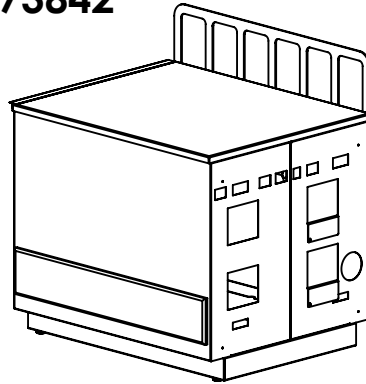

Walmart Part No.

100673746  
100673842  
100684198  
100684197  
100696212

Walmart Description

**BAGGER CAB STR 29X24**  
**BAGGER CAB AO 29X24**  
**BAGGER CAB WEDGE**  
**BAGGER CAB AO 14.5X24**  
**D82 14.5 X 23.5 X 25 BAGGER CAB STR**

**D82 14.5 X 23.5 X 25**  
**BAGGER CAB STR**  
100696212

**BAGGER CAB WEDGE**  
100684198

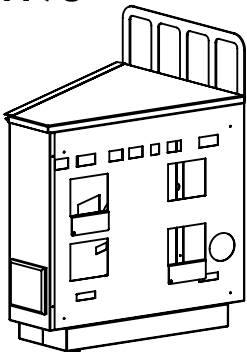

**BAGGER CAB AO 14.5X24**  
100684197

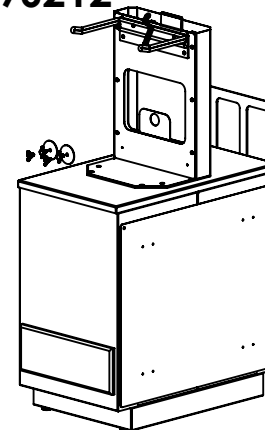
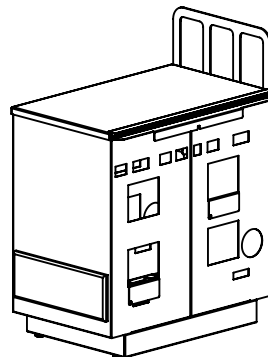

Scan QR code or visit [www.ladarling.com/bag-cabinet/](http://www.ladarling.com/bag-cabinet/) for the latest copy of the instruction sheets.

**LADARLING**

REDEFINE. RETHINK. RETAIL SOLUTIONS.

LAD DESCRIPTION  
BAGGER CABINETS

LAD PART NO.  
354421IS

REV.	BY	DATE
6	RP	4/16/24

Customer Service 1-800-682-5730

PAGE  
1 OF 6

"SHRIMP" LAYOUT (LEFT HAND CONFIGURATION SHOWN)

Step 1: Locate cabinets to approximate locations on store layout drawing. Remove end panel and counter tops.

Step 2: Install clips in window slots to connect cabinets together, as shown below. One in the front section of the cabinets, and one in the back.

Step 3: Cover seams between cabinets with gap channels.

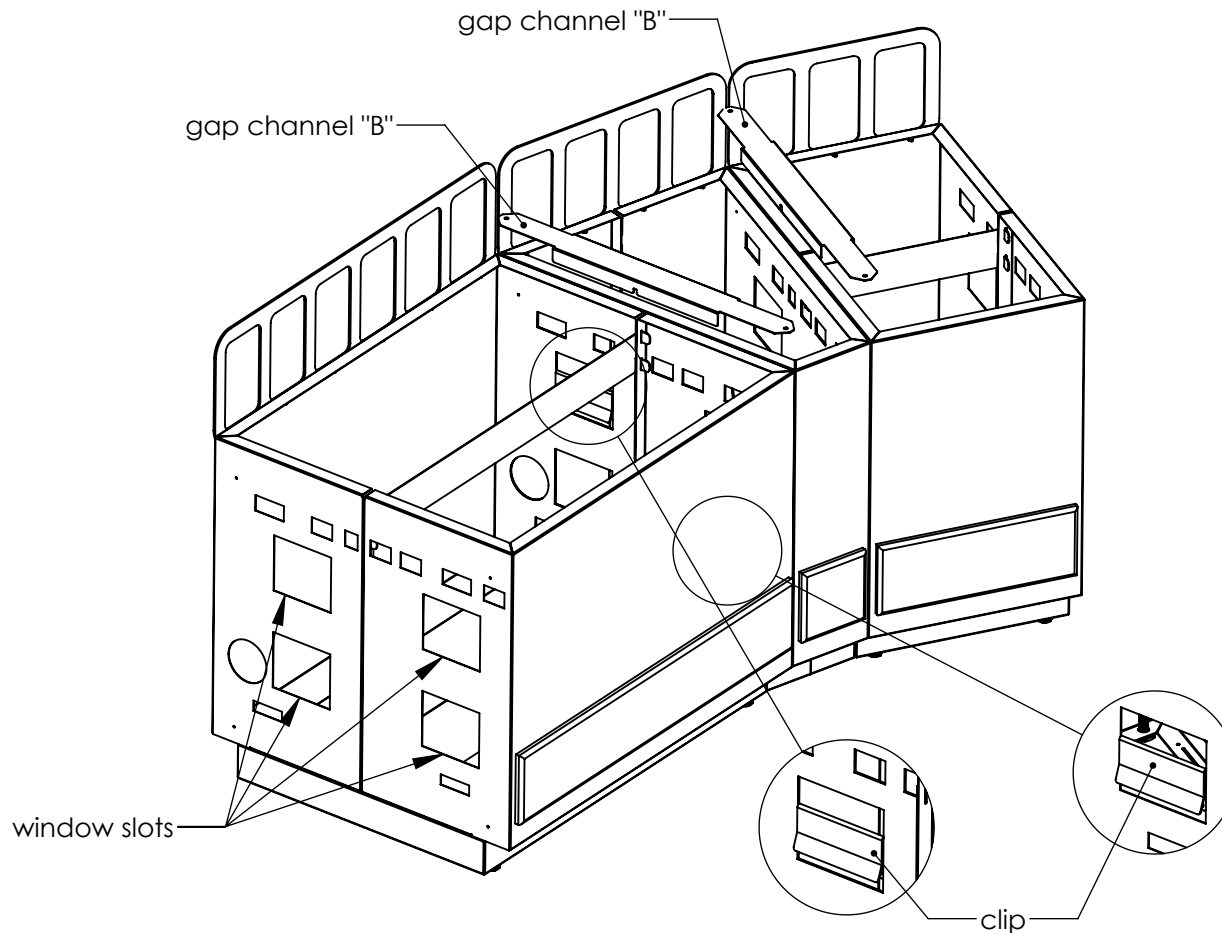

"SHRIMP" LAYOUT (LEFT HAND CONFIGURATION SHOWN)

Step 4: Install end panel in rectangular holes on end of 29X24 cabinet. Insert top clips in top rectangular holes, lift end panel, insert bottom clips into bottom rectangular holes, and then lower end panel.

Step 5: Connect 14.5X24 cabinet to checkout register with provided hardware kit. (See page 6.)

Step 6: Reinstall counter tops in cabinets. For the rectangular counter tops, the pilot holes should be positioned towards the back of the cabinets.

Step 7: Install T-channel fillers between counter tops.

Step 8: Attach first bag holder with provided wood screws on 14.5x24 cabinet.

Locate second bag holder on wedge cabinet. DO NOT attach second bag holder with screws.

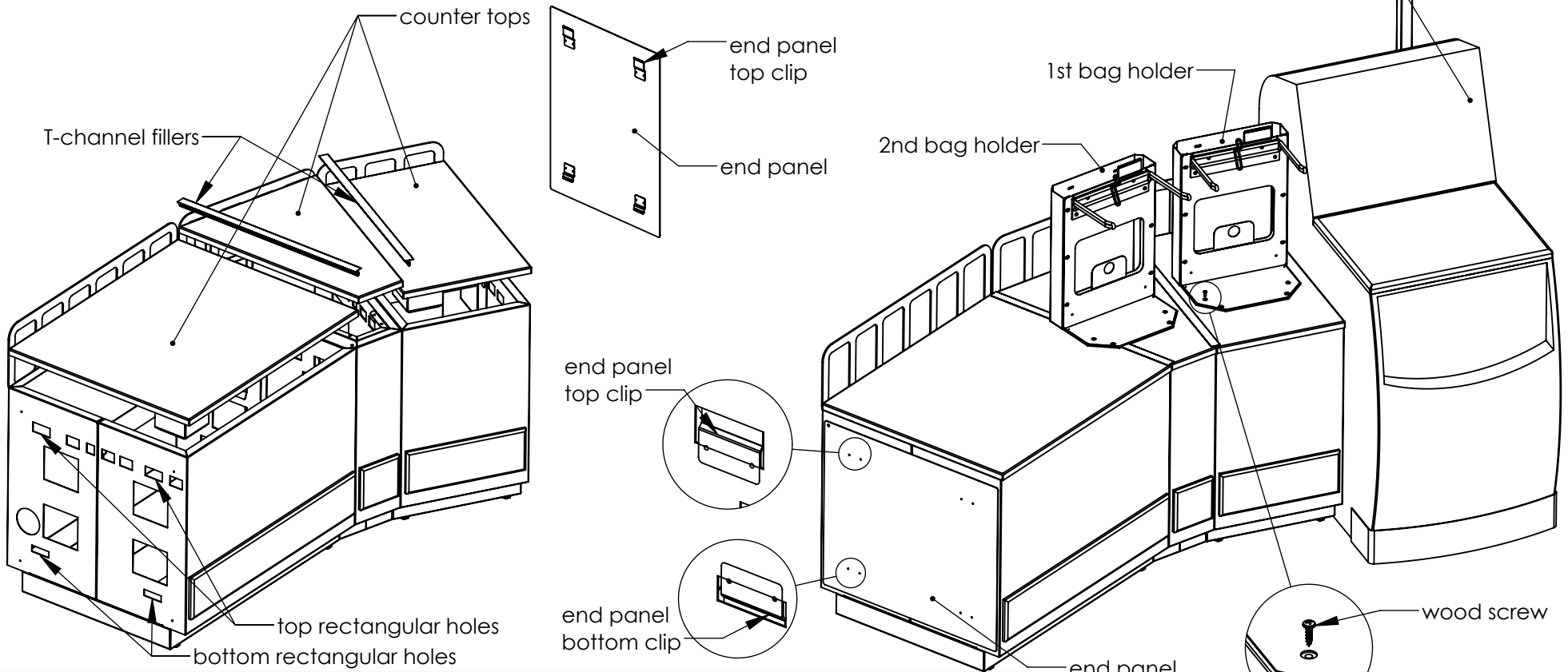

**LA DARLING**

REDEFINE. RETHINK. RETAIL SOLUTIONS.

LAD DESCRIPTION  
BAGGER CABINETS

LAD PART NO.  
354421IS

REV.	BY	DATE
6	RP	4/16/24

Customer Service 1-800-682-5730

PAGE  
3 OF 6

STRAIGHT LAYOUT (LEFT HAND, 2-SECTION CONFIGURATION SHOWN)

Step 1: Locate cabinets to approximate locations on store layout drawing. Remove counter tops and end panel, if necessary.

Step 2: Install clips in window slots to connect cabinets together, as shown below. One in the front section of the cabinets, and one in the back.

Step 3: Cover seams between cabinets with gap channels.

Step 4: Reinstall end panel in rectangular holes on end of cabinets opposite of checkout register. Insert top clip in top rectangular holes, lift end panel, insert bottom clips into bottom rectangular holes, and then lower end panel.

Step 5: Connect the cabinets to checkout register with provided hardware kit. (See page 6.)

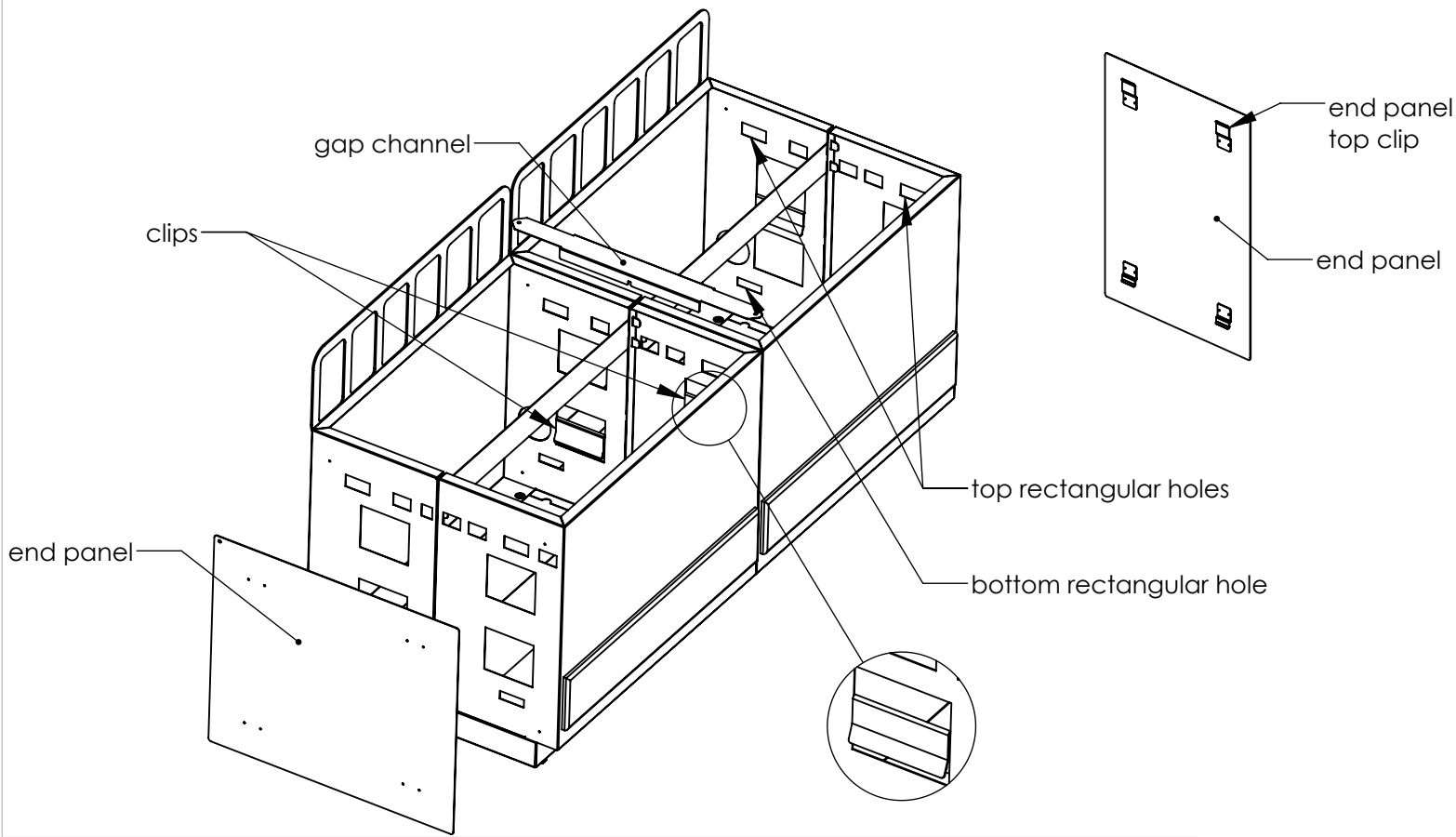

STRAIGHT LAYOUT (LEFT HAND, 2-SECTION CONFIGURATION SHOWN)

Step 6: Reinstall counter tops with the pilot holes positioned towards the back of the cabinets.

Step 7: Attach bag holders with provided wood screws on cabinet nearest checkout register.

Step 8: Install T-channel fillers between counter tops.

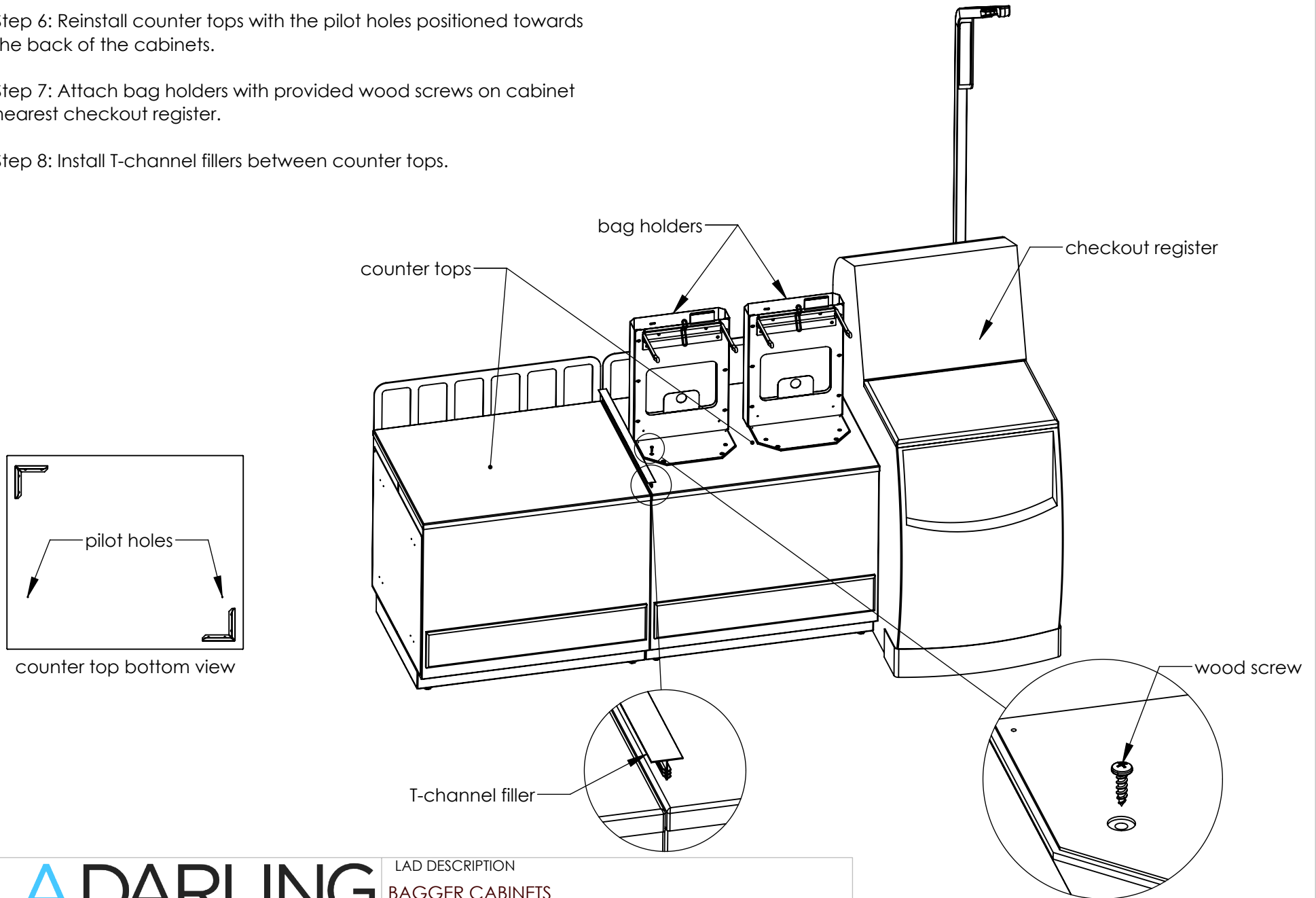

Align back of cabinet near back of checkout register so that two holes align with slots in cabinet. Note! Hardware kit contains two types of screws. Using appropriate screw type, connect cabinet to checkout register with (2) fender washers and (2) thumb screws.

